

TOS6200

Ground Bond Tester

Pursuing to maximize an easy operation, stylish design of
Ground Bond Tester



TOS6200



Adopting the constant current method to apply automated testing system

Perfect feature for the Production line which requires reduced tact time

The TOS6200 tester is designed to perform the ground bond tests required for class-I devices by safety standards such as IEC, EN, VDE, BS, UL, JIS, and the Electrical Appliance and Material Safety Low (Japan).

Equipped with a new high-efficiency power supply, it is compact and lightweight, about half the size and weight of our conventional products, while achieving a large output of 150 VA.

Use of the constant current method eliminates the need to reset test currents even in the face of fluctuating resistance values for the device being tested. The test duration can also be set from 0.3 s, making the tester suitable for production line testing, which requires reduced cycle time.

This tester is also designed for ease of use, featuring a large, easy-to-read display, memory capacity for storage of 100 types of test conditions, and incorporation of test conditions into programs to enable automatic testing. Standard GPIB and RS-232C interfaces allow the user to use PCs or other devices to control test conditions such as test current, resistance value for judgement, and test duration, and enables read-back of measured values and test results.

The tester is also provided with test leads as standard and provides high cost effectiveness.

- Test current value: 3 to 30 A AC / Resistance value: 0.001 to 1.200Ω
- Offset cancelling function
- Stores 100 test conditions in memory
- Incorporates test conditions into program
- Contact check function
- Equipped with standard GPIB and RS-232C interfaces
- Equipped with standard test lead (TL11-TOS)

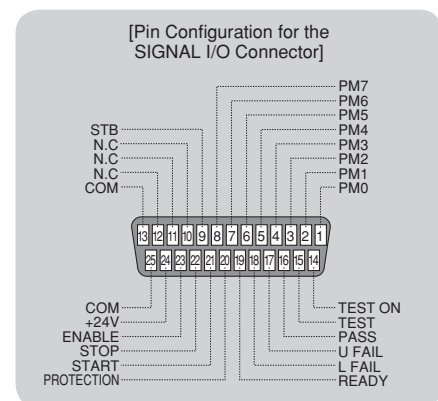

TOS6200

Ground Bond Tester

Output block		
Current setting range (*1)	3.0 to 30.0 A AC (With respect to resistance resulting in output power of the maximum rated Output or less and an output terminal voltage of 5.4 V or less)	
Resolution	0.1A	
Accuracy	± (1% of setting + 0.2A)	
Maximum rated output	150 VA (at the output terminals)	
Distortion factor	2% or less (with respect to 0.1 Ω pure resistance load of 10 A or greater)	
Frequency	50/60 Hz, sine wave (selectable)	
Accuracy	±200ppm	
Open terminal voltage	6 Vrms or less	
Output method	PWM switching method	
Output ammeter		
Measurement range	0.0 to 33.0 A AC	
Resolution	0.1A	
Accuracy	± (1% of reading + 0.2A)	
Response	Mean value response/rms value display (response time: 200 ms)	
Holding function	The current measured at the end of test is held during the PASS or FAIL interval	
Output voltmeter		
Measurement range	0.00 to 6.00 V AC	
Resolution	0.01V	
Accuracy	± (1% of reading + 0.02V)	
Response	Mean value response/rms value display (response time: 200 ms)	
Holding function	The voltage measured at the end of test is held during the PASS or FAIL interval	
Ohmmeter (*2)		
Measurement range	0.001 to 1.200 Ω	
Resolution	0.001 Ω	
Offset cancel function	0.000 to 1.200 Ω (Offset ON/OFF function provided)	
Accuracy	± (2% of reading + 0.003 Ω)	
Holding function	The resistance measured at the end of test is held during the PASS interval	
Pass/fail judgement function		
Resistance value-based judgement	Window comparator system •If a resistance value equal to or greater than the upper reference value is detected, a FAIL determination is returned. •If a resistance value equal to or less than the lower reference value is detected, a FAIL determination is returned. •If a resistance value has been judged as FAIL, the tester shuts off the output and generates a FAIL signal. •If the set time elapses without abnormalities, the tester shuts off the output and generates a PASS signal.	
Setting range for the upper reference value (UPPER)	0.001 to 1.200 Ω	
Setting range for the upper reference value (LOWER)	0.001 to 1.200 Ω	
Resolution	0.001 Ω	
Judgement accuracy	± (2% of UPPER + 0.003 Ω)	
Calibration	Calibration is performed with the rms value of the sine wave, using a pure resistance load.	
LED	PASS	Lights for approximately 0.2 sec when the measured value has been judged as PASS. It is lit continuously when the PASS holding time is set to HOLD.
	UPPER FAIL	Lights if a resistance value equal to or greater than the upper reference value is detected and judged FAIL.
	LOWER FAIL	Lights if a resistance value equal to or greater than the upper reference value is detected and judged FAIL.

External dimensional diagrams

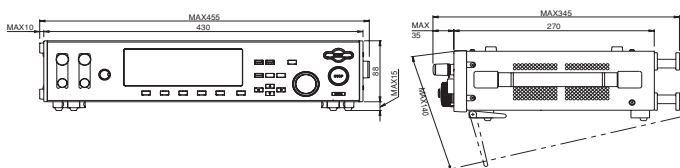

Buzzer	•The buzzer sounds for the pass holding time has been set if the measured value has been judged as PASS. •The buzzer sounds continuously under the following condition: The measured value has been judged as PASS when the PASS holding time is set to HOLD. The measured value has been judged as UPPER FAIL. The measured value has been judged as LOWER FAIL. •The buzzer volume for FAIL or PASS judgment are adjustable. Note that it cannot be adjusted individually since setting is shared with the setting for PASS.		
Time			
Test Time	Setting range	0.3 to 999 s Timer ON/OFF function is available.	
	Accuracy	± (100ppm of setting + 20ms)	
Environment			
Operating environment	Indoor use, Overvoltage Category II		
Warranty range	Temperature : 5° to 35°C Humidity : 20 %rh to 80 %rh (non condensing)		
Operating range	Temperature : 0° to 40°C Humidity : 20 %rh to 80 %rh (non condensing)		
Storage range	Temperature : -20° to 70°C Humidity : 90 %rh or less (non condensing)		
Altitude	Up to 2000m		
Power requirement			
Allowable voltage range	100 V model : 85 to 132 V AC 100 V/200 V model : 85 to 132 V AC/170 to 250 V AC		
Power consumption	At no load (READY)	100 V model : 70 VA or less	
	At rated load	100 V/200 V model : 45 VA or less	
		100 V model : 450 VA max.	
		100 V/200 V model : 330 VA max.	
Allowable frequency range	47 Hz to 63 Hz		
Insulation resistance	30MΩ min. (500 V DC), between AC line and chassis		
Hipot	1390 V AC (2 seconds), between AC line and chassis		
Ground bond	25 A AC/0.1 Ω max.		
Safety (*3)	Conforms to the requirements of the following directive and standard.		
Low Voltage Directive	73/23/EEC, EN61010-1, Class I, Pollution degree 2		
Electromagnetic compatibility (EMC) (*3,4)	Conforms to the requirements of the following directive and standard.		
EMC Directive	89/336/EEC, EN61326, EN61000-3-2, EN61000-3-3		
Under following conditions	1. Used test leadwire (TL11-TOS) which is supplied.		
	2. Used the shielded cable which length is less than three meters when the SIGNAL I/O is used.		
Physical dimensions (max)	430(455)W × 88(140)H × 270(345)Dmm		
Weight	Approx. 9kg		
Accessories			
AC power cord	1 piece		
Test leadwire TL11-TOS	1 set		
Short bar	2 pieces (These are inserted between the OUTPUT and SAMPLING terminals.)		
AC power fuse	2 pieces (2, including one spare in the fuse holder)		
Operation manual	1 copy		

*1: Time limitation with respect to output

The heat radiation capacity at the output block of the tester is designed to be one-third of the rated output, accounting for size, weight, cost, and other factors. Always use the tester within the limitation values given below. Use of the tester beyond these limits will cause the temperature of the output block to rise excessively, potentially tripping the internal protection circuit. In this case, suspend testing for approximately 30 minutes, then press the STOP switch. When temperatures fall to normal levels, the tester will revert to ready status.

Output time limitation			
Ambient temperature t (°C)	Test current I (A)	Pause time	Maximum allowable continuous test time
t ≤ 40°	15 < I ≤ 30	Equal to or greater than the test time	≤ 30 minutes
	I ≤ 15	Not required	Continuous output possible

*2: About ohmmeter's response time

A resistance value is instantaneously obtained, calculated using the measured voltage and current values. The response time of the ohmmeter complies with the response times of the voltmeter and ammeter.

*3: Not applicable to custom order models.

*4: Only on models that have CE marking on the panel.

Unit: mm