

AC/AC Frequency Converter



**EPS Stromversorgung GmbH**

Electronic Power Supplies  
Alter Postweg 101  
86159 Augsburg  
Germany

TEL +49 (0) 821/570451-0  
FAX +49 (0) 821/570451-25  
MAIL [info@eps-germany.de](mailto:info@eps-germany.de)  
WEB [www.eps-germany.de](http://www.eps-germany.de)

## USER MANUAL

Frequency Converter  
15kVA 3x200V 400Hz  
Type 140331



**EPS Stromversorgung GmbH**  
Alter Postweg 101  
86159 Augsburg  
Germany

**FON** +49 (0) 821-570 451-0  
**FAX** +49 (0) 821-570 451-25  
**MAIL** [info@eps-germany.de](mailto:info@eps-germany.de)  
**WEB** [www.eps-germany.de](http://www.eps-germany.de)



## AC/AC Frequency Converter

The manufacturer specializes in the development and production of 400Hz frequency converter. This MS/FC400 series of high quality apparatus units have been carefully designed and built to offer the best capabilities.

THIS MANUAL CONTAINS INSTRUCTIONS ON THE USE, INSTALLATION AND DEBUGGING OF THE APPARATUS. READ THE MANUAL CAREFULLY BEFORE PROCEEDING TO THE INSTALLATION, WHICH SHOULD BE CARRIED OUT BY TRAINED PERSONNEL.

THE MANUAL CONTAINS INFORMATION ON THE USE OF THE EQUIPMENT AND MUST THEREFORE BE KEPT CAREFULLY AND *CONSULTED BEFORE OPERATING THE CONVERTER.*

### **ELECTROMAGNETIC COMPATIBILITY**

The 400Hz frequency converter has the CE mark and, if used in accordance with the procedures described in this manual, comply with the EN2282, EN50091-2: EMC requirement, EMC 89/336 and 93/68 ECC directives.

The 400Hz frequency converter has been designed for professional use in industrial or commercial environments. Shielded cables must be used for connections to the REMOTE connectors.

**ATTENTION:** This is a product for restricted sales distribution to informed partners. Installation restrictions or additional measures may be needed to prevent disturbances.



## CONTENTS

<b>1</b>	<b>WARRANTY</b> .....	<b>4</b>
<b>2</b>	<b>INTRODUCTION</b> .....	<b>4</b>
2.1	PRELIMINARY OPERATION .....	5
2.2	DANGER OF ELECTROCUTION .....	5
2.3	STORAGE .....	6
2.4	PHYSICAL SET UP OF THE 400Hz FREQUENCY CONVERTER.....	6
<b>3</b>	<b>DESCRIPTION</b> .....	<b>7</b>
3.1	DESCRIPTION OF APPARATUS .....	8
3.2	TECHNICAL SPECIFICATION.....	9
3.2.1	INPUT DATA.....	9
3.2.2	OUTPUT DATA .....	9
3.3	SYSTEM PARAMETERS .....	10
3.4	STANDARDS .....	10
3.5	BREAKERS, OPERATOR CONTROLS, MEASURES, INDICATORS...	10
3.6	INPUT CABLING.....	11
3.7	EARTHING.....	11
3.8	OUTPUT CABLING .....	12
3.9	START UP PROCEDURE.....	12
3.10	SHUTDOWN PROCEDURE .....	12
3.11	MAINTENANCE OF FREQUENCY CONVERTER.....	13
3.12	ANOMALIES .....	13



## 1 WARRANTY

The apparatus is guaranteed from defect of materials and defect in workmanships within bounds of right working.

If within the warranty period, the apparatus was defective, The manufacturer would repair or substitute, free of charge, the damage part, ex our works, on condition that a written request arrived within 8 days since the remark of defect.

The warranty will be not applied in the following situations:

Without a proper installation (inadequate air conditioning, high temperatures, dusty and corrosive ambient);

If a whatever part of the apparatus has repaired or manipulated by not qualified and authorized personnel;

If it turns out that the cause of the fault is due to negligence of not qualified personnel or to bad working of other apparatus (conditioners, fans..);

If it turns out that the cause of the fault is due to events as: thunderbolts, fires, earthquakes, inundations or other disasters;

REMARK: Ordinary maintenance, if it is not provided in the purchase contract, is charged to customer even during warranty period.

The apparatus has to maintain clean observing the safety instructions described in the chapter "MAINTENANCE".

## 2 INTRODUCTION

This technical manual contains all the necessary information for the correct use of the apparatus. If a fault or a bad working happens, our Customer Service will provide authorized electricians or qualified internal personnel to perform the necessary operations. In case of conflict between this manual and drawings or purchase orders, the manual NOT has priority. If errors would be notified upon the content of this manual, these ones had to be communicated to Engineering Department in order to substitute the relative part.



## 2.1 PRELIMINARY OPERATION

### Reception

The packing container serves to protect the apparatus from mechanical and climatic impacts. To increase its protection the apparatus is wrapped with a plastic sheet. Upon receiving the apparatus, carefully examine the packing container and the 400Hz frequency converter for any sign of physical damage. Ensure that the received apparatus corresponds to the material indicated in the delivery note.

### Nameplate

The technical specifications of the apparatus are provided on the nameplate which is situated at the back of the frequency converter.

### Unpacking

Perform the following steps to unpack the 400Hz frequency converter:

Remove the wood grates

Remove the plastic cover from the apparatus

Remove the apparatus from the pallet

Make sure you retain the packaging materials for future shipment of the apparatus

Examine the apparatus for any sign of damage. Notify your dealer immediately if damage is present.

## 2.2 DANGER OF ELECTROCUTION

### Safety precautions and regulations

This section of the manual describes safety precautions that should be followed scrupulously.

**THE CONVERTER MUST NEVER BE USED WITHOUT AN EARTH CONNECTION.**

The first operation is to connect the earth connector to the terminal marked yellow/green.

Inside the apparatus there are some voltage potentials which are dangerous for health bodily. We exhort to allow the admittance at the apparatus only to expert personnel. Before starting any maintenance operations it is necessary wait for the discharge of electrolytic capacitors and **IT IS NECESSARY MEASURE THEIR VOLTAGE BEFORE TOUCHING THEM.** All installation and maintenance operations must be carried out exclusively by qualified personnel.

Make sure that water or other liquids and/or foreign objects do not enter the Converter unit.



## **2.3 STORAGE**

If you plan to store the 400Hz frequency converter prior to use, store it unpacked in a storage environment with a temperature between -40°C to +60°C and humidity of less than 95%. If the packing container is removed protect the apparatus from dust.

## **2.4 PHYSICAL SET UP OF THE 400Hz FREQUENCY CONVERTER**

The FC400 can easily be moved to its final position.

We advise you to move the apparatus to a position where:  
the humidity and temperature are within prescribed limits;  
the fire protection standards are respected;

We recommend longer connecting cables to enable moving of the apparatus (in case it must be opened) without a prior shutdown.  
the cabling can be performed easily;  
there is enough room for to easily operate the UPS and if necessary to perform periodic maintenance.



### 3 DESCRIPTION

- Description of apparatus.
- Technical specification
- Input cabling
- Earthing
- Output cabling
- Start up procedure
- Shutdown procedure
- Maintenance of the Frequency Converter
- Anomalies
- Meter description
- Schematics
- Auxiliaries



### **3.1 DESCRIPTION OF APPARATUS**

The 180208 sch.3 block diagram describes the apparatus.

A diode rectifier transforms the ac voltage into a continuous stabilized DC link voltage, to power the IGBT inverter that transforms the continuous voltage into a 400Hz alternating sinusoidal stabilized voltage with a PWM modulation. The output inverter voltage feeds a transformer which on its output have the filter capacitors.

The output voltage is sinusoidal with a distortion of 3%. The output has an electronic stabilization both in voltage and in frequency.





## 3.2 TECHNICAL SPECIFICATION

### 3.2.1 INPUT DATA

- Rated voltage:	400V
- Number of phases:	3 ph, 3W
- Voltage range:	+/-15%
- Frequency:	50/60Hz
- Frequency range:	± 15%
- Input current at full load:	22.5A
- Power factor:	0.94
- Total Current Harmonic Distortion at rated load:	30%
- Inrush current:	absent

### 3.2.2 OUTPUT DATA

- Rated power:	15kVA
- Load power factor:	0,8 lagging corresponding 20kW
- Rating:	continuous
- Rated voltage:	200/115V 4w
- Frequency:	400Hz
- Frequency stability:	± 0.5%
- Users power factor:	ind./cap.
- Waveform:	sinusoidal
- Voltage Total Harmonic Distortion (on linear load):	3%
- Voltage regulation :	± 1%
- Voltage transient (for load step 0-100% and back):	± 8%
- Recovery time:	10 msec.
- Overload 10 minutes:	1.25 of full load
- Overload 1 minute:	1.5 of full load
- Phase voltage symmetry with balanced load:	± 1%
- Phase voltage symmetry with unbalanced load (I <sub>r</sub> ; 0.3 I <sub>r</sub> ; 0.3 I <sub>r</sub> ):	± 2%



### 3.3 SYSTEM PARAMETERS

- Dimensions:	600x800x1200mm
- Weight:	200kg
- efficiency:	89%
- Audible noise (ISO/376):	65dBA
- Operating temperature:	-25°C to +45°C
- Non operating temperature:	-40°C a +60°C
- Relative humidity ( non-condensing):	0 to 95%
- Altitude without derating:	1000m msl
- Enclosure:	IP 21
- Painting:	RAL 7035
- Cooling:	forced air

### 3.4 STANDARDS

FAA Advisory Circular : Specification for constant current regulators and regulator monitors  
CE compliant.

MIL-STD 704E

EN 50231 CCR: equipment specifications and test

IEC 61822: Electrical installation for lighting and beaconing of aerodromes-CCR

EN50091-1 : safety requirements

EN 61000-6-2: Electromagnetic compatibility. Emission

EN 61000-6-4: Electromagnetic compatibility. Immunity.

### 3.5 BREAKERS, OPERATOR CONTROLS, MEASURES, INDICATORS

- Input circuit breaker
- Output switch
- ON/OFF input switch operator
- Measures:
  - output voltage
  - output current
  - output frequency
- Indicators:
  - mains
  - frequency converter running
  - frequency converter alarm
- Emergency push button



### 3.6 INPUT CABLING

Before you start the cabling of the FC400 make sure you have determined the correct POWER and INPUT CONFIGURATION of your 400Hz frequency converter.

To achieve a correct operation of the apparatus and its additional equipment it is necessary to provide the mains lines with appropriate fuse protection.

Before you start connecting the FC400 make sure, that:  
the values of the mains voltage (INPUT VOLT.) and frequency (FREQUENCY) correspond to the values indicated on the nameplate of the apparatus the earthing is performed in accordance with prescribed IEC Standards or with the local regulations

Provide a circuit breaker or a special line protection with following characteristics:  
with the same or higher value as indicated on nameplate on the rear of the FC400 (INPUT POWER) or in accordance with prescribed IEC Standards or with local regulations for circuit breakers curve "D".

### 3.7 EARTHING

To ensure protection of the personnel during the installation of the apparatus make sure that the connections are performed under the following conditions:

- no mains voltage is present
- the loads are shut down
- FC400 converter is shut down and voltage-free

Unscrew both screws of the terminal cover plate and remove the terminal cover plate.

#### **ATTENTION:**

The earthing is guarantee by special screws, don't replaced them with standard ones.



### 3.8 OUTPUT CABLING

Before you start performing the connection sequence of the loads ensure that the indicated FC400 converter rated power (OUTPUT POWER) on the nameplate (on the rear side of the apparatus) is equal or larger than the total load requirements. It is necessary to provide the output of the apparatus with a **circuit breaker** or other kind of protection. The circuit breaker will be connected between the loads and the FC400 converter and will therefore protect the apparatus additionally from overloads and short circuits. The circuit breaker must comply with the prescribed IEC Standards.

Ensure that the earthing is performed in accordance with the prescribed IEC Standards or with the local regulations.

### 3.9 START UP PROCEDURE

Upon receiving the frequency converter, carefully examine the packing container and the Frequency converter for any sign of physical damage.

- Check input breaker is in OFF position.
- Connect input and output cables.
- Close Q1 input breaker. Blower are in operation. The blue LED must come on. Inverter filter capacitor are charged.
- Put switch operator in ON position.
- H2 RUNNING lamp and H1 ALARM lamp are lighted.
- After 10 secs K1 is closed
- After others 7 secs the converter is in function and H1 come off.
- When converter is OK, it is possible to connect output switch.

### 3.10 SHUTDOWN PROCEDURE

- Put the switch operator in **OFF** position.
- Open output switch S1.
- Open input switch, Q1, to isolate the converter.



### 3.11 MAINTENANCE OF FREQUENCY CONVERTER

After having started up the apparatus in the right way, it doesn't need any particular care: however it is necessary that the ambient, where the frequency converter is placed, must be airy and without dust. It is important after the first six months to carry out a check of the apparatus to verify its cleanness; if the accumulated dust on radiators is excessive, it is necessary to remove this one with dry low compressed air. For normal environment, it had better clean the apparatus al least yearly.

### 3.12 ANOMALIES

If during the start up procedure a problem occurs, let do the following controls:

- When Q1 is closed, verify that:
- The Blue LED lights up. If not, check F5 and F6 (10x38 6 A fuses);
- The fans must come on. If not, check Q2, Q3, Q4.
- The P1 meter must light up. If not, check F7 (10x38 1A fuse);

When you put the switch operator in ON position, check:

- KT timer comes green lighted; timer start the 10 seconds countdown . After 12 seconds yellow led of KT is lighted.
- K1 contactor is excited. If not, check that: the EPO push bottom in OFF position, the thermo switches of the inverter radiators and rectifier radiators are closed. The thermo switch of the transformer is closed.
- Check on AICO card the LEDS V51 and V52 are lighted on. If not, it is probably that this is an heavy fault, it is necessary call the service.
- Check on ALUP card, the LED V48 is lighted on yellow and V45+V46 are lighted on green. If only the yellow LED is lighted (the two green LEDs are OFF) check the fuse F4 (10x38 1 A rapid fuse). Try to substitute it . If this fuse goes on to burn, stop your procedure in order to avoid damages to the apparatus.
- After 7 seconds the LED V96 on Core card must be lighted. If this LED doesn't light on or one of the red LEDS V98, V99, V100, check the connections but not repeat the operation in order to avoid damages to the apparatus.

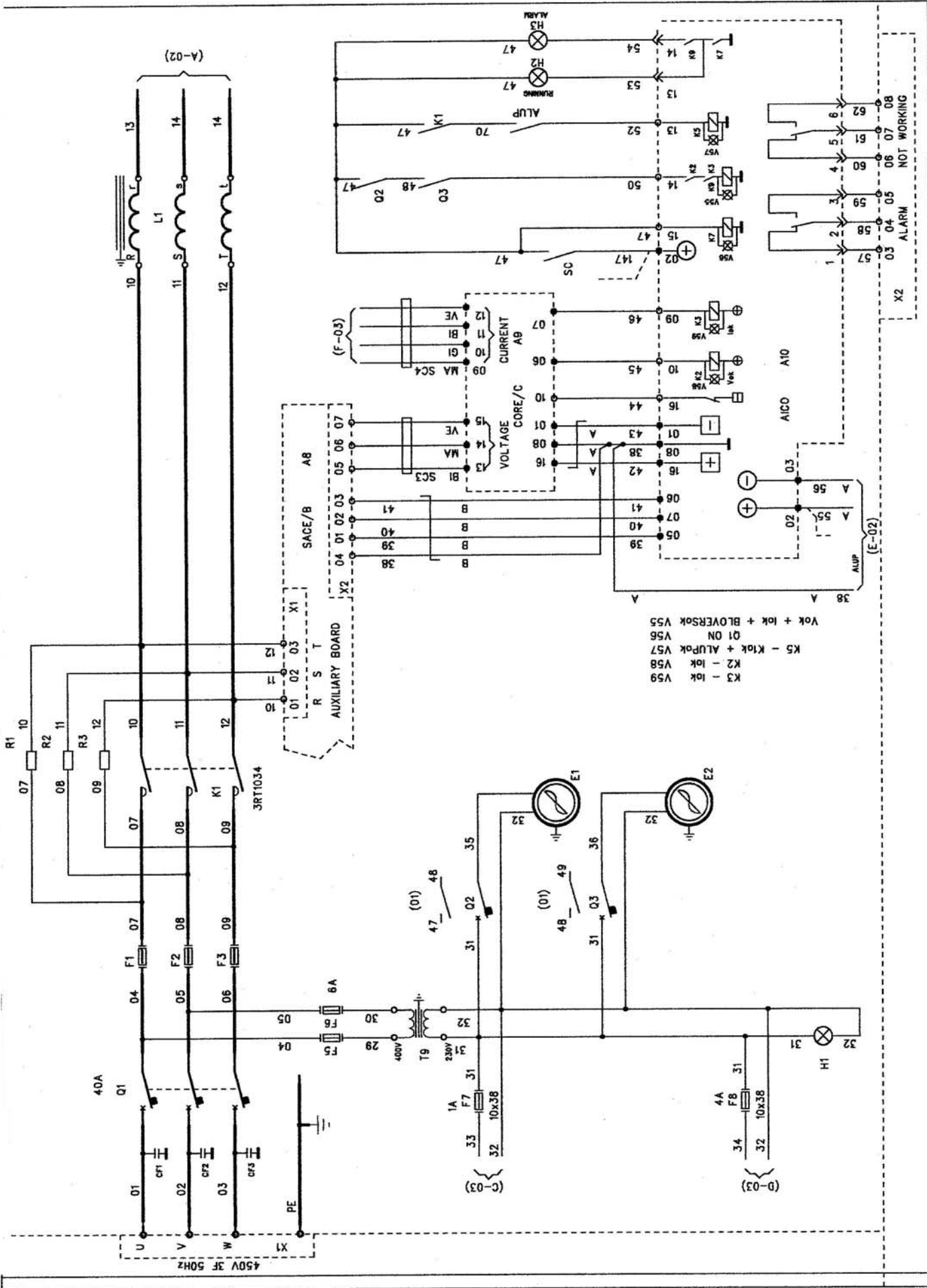

Vok + lok + BLOVERSOK V55  
 Q1 ON V56  
 K5 - Klok + ALUPok V57  
 K2 - lok V58  
 K3 - lok V59

# EPS Stromversorgung GmbH

REV.A	CODE	140331	SH.1
-------	------	--------	------

FREQUENCY CONVERTER 15kVA - 3x200V - 400Hz

NOTE

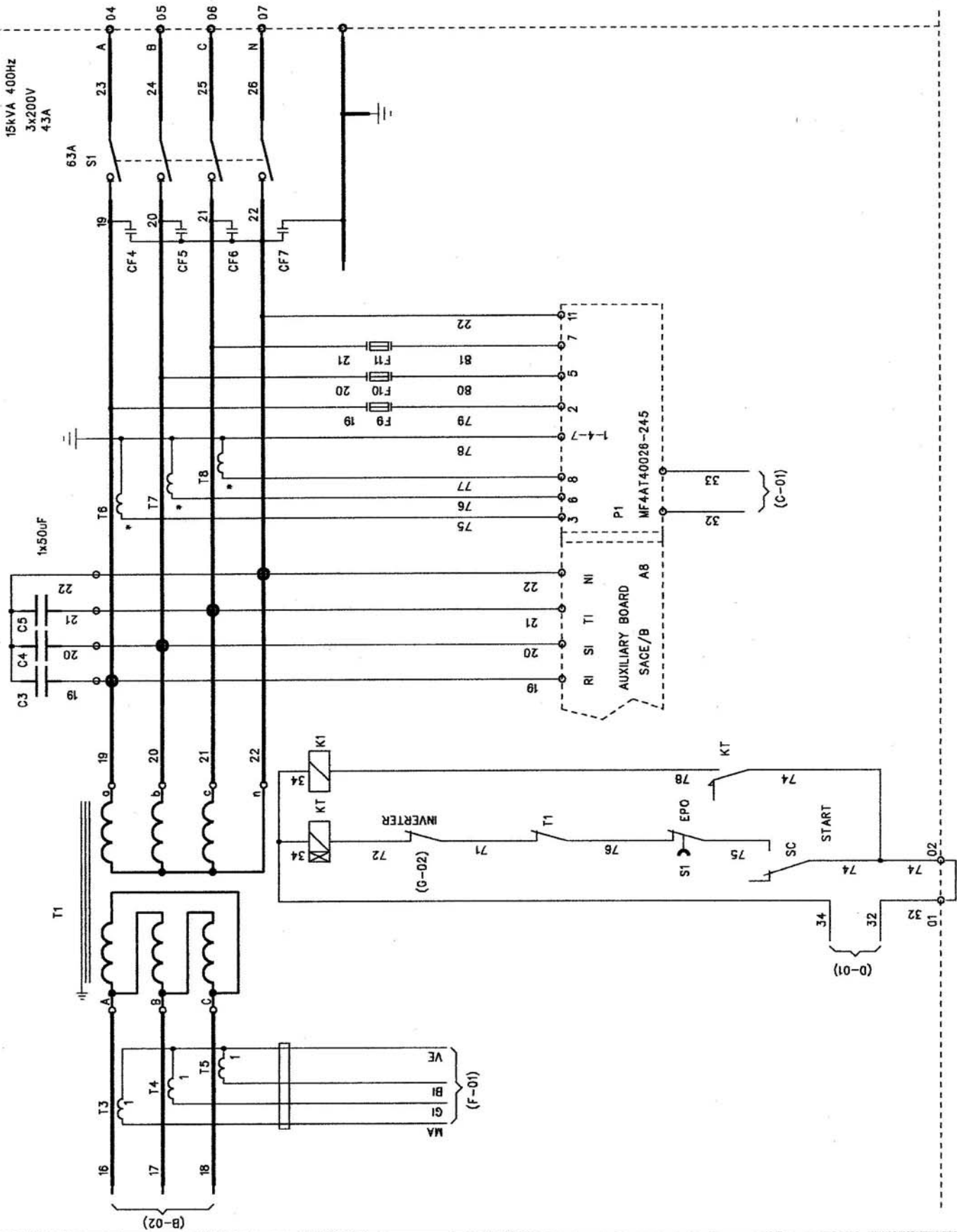

NOTE

CODE 140331

SH.3

EPS Stromversorgung GmbH

FREQUENCY CONVERTER 15kVA - 3x200V - 400HZ

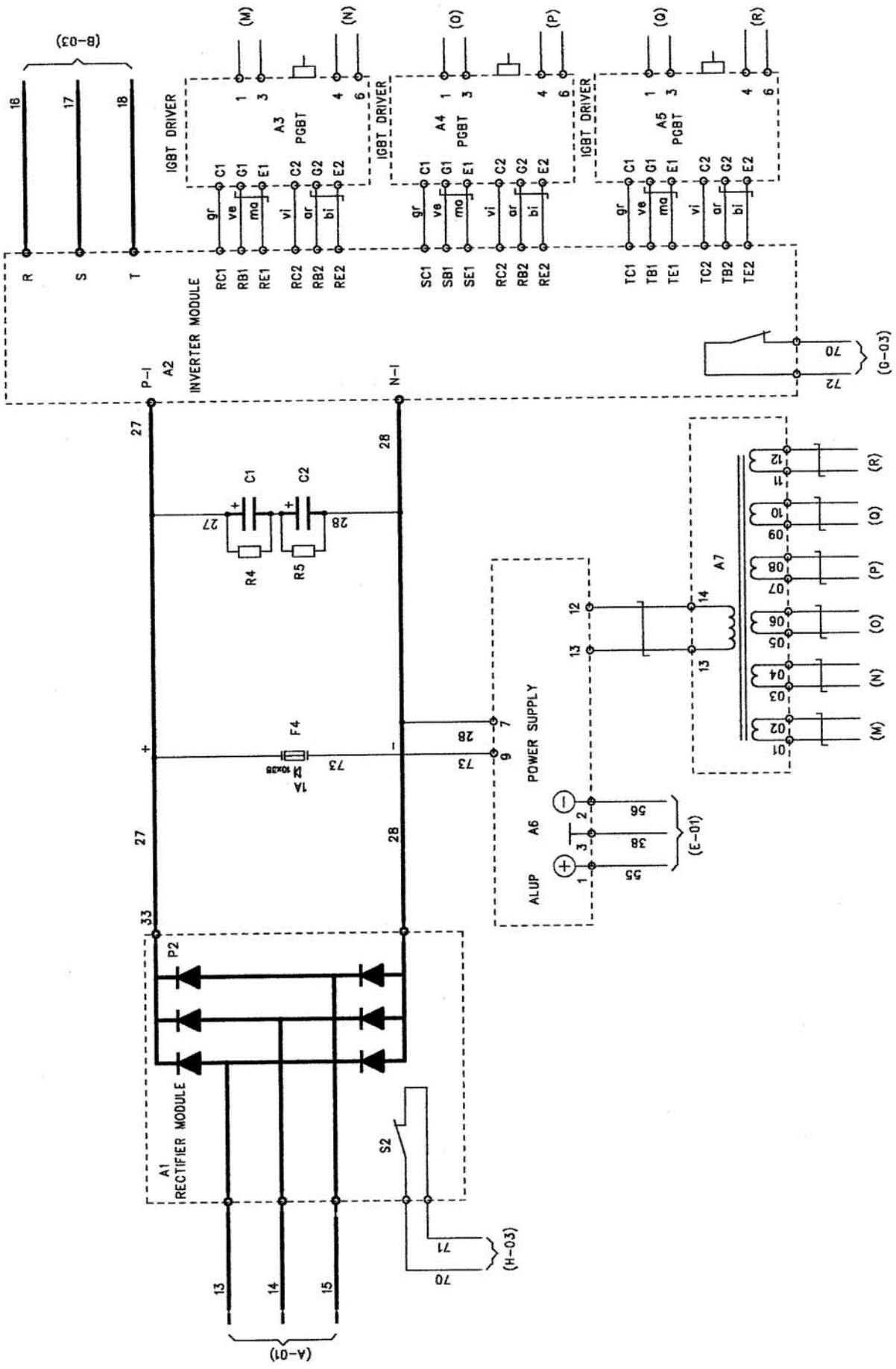

ALUP A6	CODE	140331	SH.2
FREQUENCY CONVERTER 15kVA - 3x200V - 400Hz			